



MANUAL TRANSFER SWITCHES

Highly **durable**, easy to **use** and uncompromisingly **safe**.

**RELIABLE
PERFORMANCE EVEN
WITH FREQUENT
USE AND HARSH
ENVIRONMENTS.**

- Available from 63A -1600A up to 600V AC
- Conformity to IS/IEC 60947-3
- High short-circuit withstand capacity
- 3 position center-off switch is robust and easy to use
- Modular and compact design
- Reliable and maintenance free operation.
- Available in 3 pole / 4 pole version

**EASY TO USE
FOR QUICK
AND EFFICIENT
SWITCHING OF
POWER.**

- Open transition on load transfer between two sources
- High electrical and mechanical life
- Customized Incoming and Outgoing Terminal interchangeability
- Terminal shrouds and phase barriers provides complete safety
- Rugged design to compact environmental conditions

**SAFE DESIGN TO
PREVENT FROM
ELECTRICAL SHOCK
TO PERSONNEL
OR FIRE.**

- Utilization category - AC 23 (Withstand high in-rush current)
- Design to withstand high thermal condition
- Tolerance to high electrical and mechanical characteristics
- Isolation pad lock for maintenance operations
- Maintenance free self cleaning contacts
- Auxiliary indication contacts for source 1 and source 2



Rugged industrial design



Wide range of applications



AUXILIARY
Indication contact

MANUALLY CONTROL YOUR POWER SOURCE

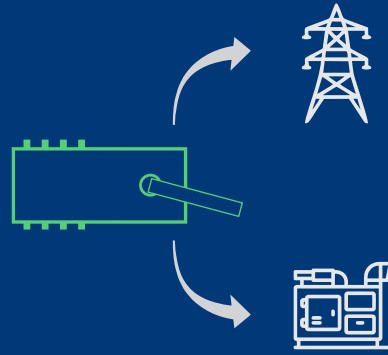

Features

- Wide range from 63 to 630A (3 Pole & 4 Pole Version)
- Utilization category AC 23A (With high in-rush current)
- Operating handle with provision to lock in ON/OFF position
- User-friendly installation and operation
- Quick-make & quick-break operation for transferring of loads
- Incoming and outgoing terminal interchangeability
- Terminals suitable for aluminum and copper conductor Connectivity.
- Inbuilt Mechanical Limit switch for External indication (1 NO & 1 NC)
- Conforms IEC 60947- 6-1 Up to AC -33B, IS/ IEC 60947-3 Up to AC 23A, Front operated 3 pole & 4 pole 415V 50HZ
- Maintenance free most reliable mechanically held contact technology
- High short circuit with stand capacity

Applications

- Generator OEM's
- Commercial buildings
- Automobile Industry
- Manufacturing Industry
- Power distribution and Load Management
- Healthcare
- Emergency / bypass systems
- Server rooms

Mechanical Specification 63A - 630A

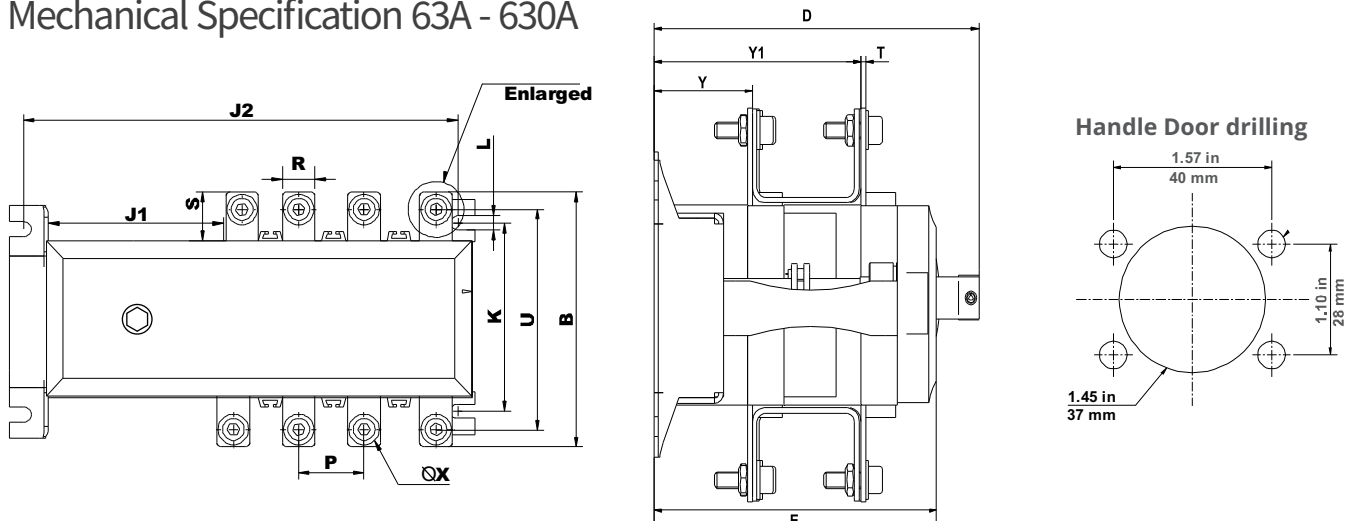

SIZE	Specifications	Dimensions Details														
	63A-630A 4 POLE MTS	B	D	E	J1	J2	K	L	P	R	S	T	U	OX	Y	Y1
Frame -1	MTS-63A	116	140	125	82	200	86	6.5	30	13	23	2.5	103	8	42	92
	MTS-100A	116	140	125	82	200	86	6.5	30	13	23	2.5	103	8	42	92
	MTS-FR1-125A	116	140	125	82	200	86	6.5	30	13	23	2.5	103	8	42	92
Frame -2	*MTS-FR2-125A	135	185	165	97	257	102	6.5	35	22	26	3.5	115	8	57	127
	MTS- 160A	135	185	165	95	260	104	6.5	38	20	25	3.5	115	8	56	126
	MTS-200A	152	185	165	95	260	104	6.5	55	25	33	3.5	148	10.8	72	153
Frame -3	MTS-250A	185	215	200	95	305	110	6.5	55	30	40	3.5	148	10.8	72	153
	MTS-315A	185	215	200	95	305	108	6.5	55	30	40	3.5	148	12	72	152
Frame -4	MTS-400A	241	265	245	110	385	180	9.5	72	40	40	5	205	12	83	195
	MTS-630A	260	265	245	117	385	180	9.5	65	42	55	6	225	12	83	195

Technical Specification

MTS	63A	100A	125A	160A	200A	250A	315A	400A	630A
Thermal Current I_{th} (40°C)									
Number of Poles	3P/4P	3P/4P	3P/4P	3P/4P	3P/4P	3P/4P	3P/4P	3P/4P	3P/4P
Max. Normal Rating of Fuses	63	100	125	160	200	250	315	400	630
Insulation Voltage U _i (V)	750	750	750	750	1000	1000	1000	1000	1000
Dielectric Strength (V) 50Hz 1mn.	4000	4000	5000	5000	5000	5000	5000	8000	8000
Impulse Voltage (kV)	6	6	6	6	8	8	8	12	12
Rated Operational Currents I_e (A)									
415 VAC-AC 23A	63	100	125	160	200	250	320	400	630
500 VAC-AC 23A	55	55	100	130	160	200	250	315	315
440 VDC-DC 21A	63	100	125	160	200	250	320	400	500
440 VDC-DC 22A	63	100	125	130	160	200	250	400	500
440 CDC-DC 23A	63	63	125	130	160	200	250	400	500
Protection									
Short-circuit Current with Fuses (kA rms)	80	80	80	80	80	80	80	80	80
Fuse Rating	63	100	125	160	200	250	315	400	630
Peak Short-circuit making capacity (kA rms)	15	15	20	20	20	30	45	45	45
Admissible Short time current 1 sec (kA rms)	5	5	7	7	7	9	13	13	13
Making & Breaking Characteristics									
Breaking Capacity (Arms) 415 VAC PF-0.35	504	504	1000	1280	1600	2000	2520	3200	5040
Making Capacity (Arms) 415 VAC PF-0.35	630	630	1250	1600	2000	2500	3150	4000	6300
Endurance									
Mechanical No. of operations	10000	10000	8000	8000	8000	8000	5000	5000	5000
Electrical No. of operations	2500	1500	1000	1000	1000	1000	1000	1000	1000
Operating Force (Nm)	3.5	3.5	9.5	9.5	9.5	11	11	17	17
Connection									
Min. Cu Cable / Bus Bar size (mm ²)	16	35	50	70	95	120	185	240	40 x 8
Min. Al Cable / Bus Bar size (mm ²)	25	2 x 25	70	95	150	185	240	300	40 x 8 x 2

Mechanical Specification 800A -3200A

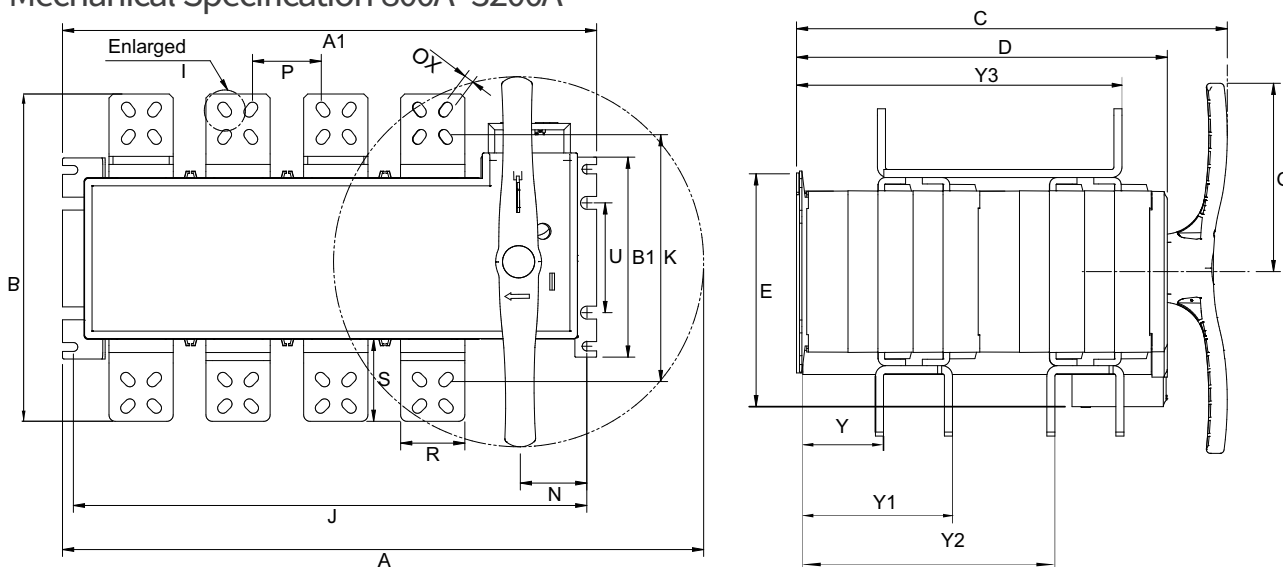

Specification	Outline Size (mm)						Mounting Size (mm)															
	A	A1	B	B1	C	D	E	G	J	K	L	N	P	R	S	T	U	ØX	Y	Y1	Y2	Y3
ATeS-800A-3200A	845	665	350	220	400	248.3	373	450	645	220	12	85	120	60	64	8	250	12	103	227	330	427
ATeS-800A	845	665	350	220	400	248.3	373	450	645	220	12	85	120	60	64	8	250	12	103	227	330	427
ATeS-1000A	845	665	350	220	400	248.3	373	450	645	220	12	85	120	60	64	8	250	12	103	227	330	427
ATeS-1250A	845	665	355	220	400	248.3	373	450	645	220	12	85	120	80	72	8	250	13	103	227	330	427
ATeS-1600A	845	665	355	220	400	248.3	373	450	645	220	12	85	120	80	72	10	250	13	103	227	330	427
ATeS-2000A	845	665	355	220	530	448.1	373	450	645	220	12	85	120	80	72	10	250	13	103	227	330	427
ATeS-2500A	845	665	384	220	530	448.1	373	450	645	220	12	85	120	80	90	15	250	13	103	227	330	427
ATeS-3200A	845	665	384	220	530	448.1	373	450	645	220	12	85	120	120	90	15	250	13	103	227	330	427

Technical Specification

MTS	800A	1000A	1250A	1600A	2000A	2500A	3200A
Thermal Current I_{th} (40°C)							
Number of Poles	3P/4P	3P/4P	3P/4P	3P/4P	3P/4P	3P/4P	3P/4P
Max. Normal Rating of Fuses	800	1000	1250	1600	2000	2500	3200
Insulation Voltage U _i (V)	1000	1000	1000	1000	1000	1000	1000
Dielectric Strength (V) 50Hz 1mn.	5000	5000	5000	5000	5000	5000	5000
Impulse Voltage (kV)	12	12	12	12	12	12	12
Rated Operational Currents I_e (A)							
415 VAC-AC 23A	800	1000	1250	1600	2000	2500	3000
500 VAC-AC 23A	630	1000	1000	1000	1000	1000	1000
440 VDC-DC 21A	630	1000	1250	1600	2000	2000	2000
440 VDC-DC 22A	800	1000	1250	1250	1250	1250	1250
440 CDC-DC 23A	800	1000	1000	1000	1000	1000	1000
Protection							
Short-circuit Current with Fuses (kA rms)	80	80	80	80	80	80	80
Fuse Rating	800	1000	1250	2x800	2x1000	2x1250	2x1600
Peak Short-circuit making capacity (kA rms)	55	105	105	110	110	110	120
Admissible Short time current 1 sec (kA rms)	26	50	50	50	50	50	50
Making & Breaking Characteristics							
Breaking Capacity (Arms) 415 VAC PF-0.35	6400	8000	8000	8000	10000	10000	10000
Making Capacity (Arms) 415 VAC PF-0.35	8000	1000	10000	10000	12500	12500	12500
Endurance							
Mechanical No. of operations	4000	4000	4000	3000	3000	2500	2500
Electrical No. of operations	500	500	500	500	500	500	500
Operating Force (Nm)	40	40	40	40	60	60	60
Connection							
Min. Cu Cable / Bus Bar size (mm ²)	50x5x2	60x5x2	80x5x2	100x5x2	100x5x3	100x5x4	100x10x3
Min. Al Cable / Bus Bar size (mm ²)	50x8x2	50x10x2	63x12x2	100x8x2	100x10x3	100x10x4	100x10x5